



Pacrim13 Corporate Sponsorship Application Guidelines

1. Sponsorship application period : May, 2018-July 31, 2019

2. How sponsorship income will be used

Income from sponsorships will be used for costs in the preparation and operation of Pacrim13. However, if sponsors designate a particular symposium, their sponsorship money will be allocated for operation of that symposium, including remuneration for invited speakers, transportation expenses and other miscellaneous costs.

(Costs for creating advertisements and banners will be deducted from the sponsorship income before it is provided to the designated symposium.)

3. How to apply to be a sponsor

Sponsorship is divided into 4 categories - Diamond, Gold, Silver, and Bronze, in accordance with the amount paid by sponsors. Please specify your desired category on the application form (MS Excel format), which can be downloaded from the following URL, and send it by email to the address shown below.

URL : http://www.ceramic.or.jp/pacrim13/sponsorship_form_en.xlsx

The Ceramic Society of Japan

Email : pacrim13_sponsor@cersj.org

Sponsorship Categories	
<p>■Diamond (1,000,000 yen or more)</p> <ul style="list-style-type: none"> • Logo (extra large) displayed near main registration area • Logo (extra large) and link on the PACRIM 13 website • Full page color ad in conference program • Logo on conference bag 	<p>■Gold (500,000 yen)</p> <ul style="list-style-type: none"> • Logo (large) displayed near main registration area • Logo (large) and link on the PACRIM 13 website • Full page color ad in conference program
<p>■Silver (300,000 yen)</p> <ul style="list-style-type: none"> • Logo (medium-size) displayed near main registration area • Logo (medium-size) and link on the PACRIM 13 website • Half-page color ad in conference program 	<p>■Bronze (150,000 yen)</p> <ul style="list-style-type: none"> • Logo (small-size) displayed near main registration area • Logo (small-size) and link on the PACRIM 13 website • Half-page black and white ad in conference program

In addition to the above, an exhibition booth will be provided by paying the actual equipment cost of **25,000 yen**.

Ex: If you apply for bronze sponsorship and you wish to have a exhibition booth,
150,000 yen + 25000 yen = 175,000yen

(We do not accept application for exhibition only)

- Number of booth: 20 booth on a first-come, first-served basis
 - Place: Poster presentation hall
 - Period: 14:00 October 28, 2019 to 14:00 on October 31 2019
- Booth equipment: See the figure below



Size & Equipment of Exhibition Booth (unit: mm)

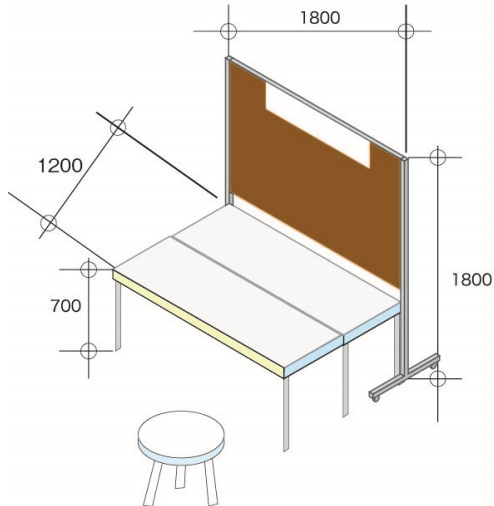

4. Payment Details

Invoices will be sent to applicants who request it on their application forms.

Applicants who do not require an invoice can pay by direct deposit into the bank account listed below.

Account holder's name: Nippon Seramikkusu Kyokai (The Ceramic Society of Japan)

Bank Account: No.0005-469-3935016, SWIFT code: BOTKJPJT

MUFG Bank, Ltd., Shinjuku-Chuo Branch, Tokyo JAPAN